

Ledyard Public Schools
4 Blonders Blvd Ledyard, CT 06339
Midmark Space Savers and Cat Towers
Bid # LPS 24-2

Ledyard Public Schools is seeking bids from qualified bidders for the purchase of Midmark Space Savers and Cat Towers for Ledyard High School Agricultural Science Program.

Bidders can provide bids for Comparable materials provided they meet or exceed the Midmark standards. Bidders should supply cut sheets and manufacturer specifications for any alternate submissions

Bidder should be advised that space is critical and the measurements provided on the attached drawings can not be exceeded.

Bid packages are available on the district website at www.ledyard.net or can be obtained by emailing Wayne Donaldson Ledyard Public Schools Facilities Director at Wdonaldson@ledyard.net. Sealed bid submissions are due on Thursday March 28, 2024 by 11AM. Bids must be received at Ledyard Public Schools 4 Blonders Blvd. Ledyard, CT 06339 Attn: Wayne Donaldson before the assigned date and time at which time the bids will be publicly opened. Bids submitted after the deadline will not be considered. Please enclose your bid in a sealed envelope clearly marked with the Bid number and name. Questions can be emailed to wdonaldson@ledyard.net until 3PM on Friday March 22, 2024. ***(All questions must be in writing or email addressed only to the Director of Facilities)*** Ledyard Public Schools reserves the right to waive minor discrepancies in bids or to accept or reject all or part of any submission. All bid submissions are the property of Ledyard Public Schools and will not be returned to the bidder. Award notification to the successful bidder is expected on or before Friday April 12, 2024.

. Bid packages are available on the Ledyard Board of Education web site www.ledyard.net listed under district/finance/bids 2023-24. The response to all questions will be posted on the district website as addendums. It is each bidders responsibility to verify the website for addendums and sign off acknowledgement of receipt. ***(Down loading the bid from the BoE website will not ensure receipt of any addendums)***

Bids are to include all shipping and handling costs for delivery to Ledyard High School 24 Gallup Hill Rd Ledyard, CT 06351. Standard delivery times are 7AM-2PM week days. Forklift is available for unloading lift gate delivery is not required.

All bids must contain a certification stating that the bid amount is valid for a period of 90 days from bid opening date. The successful bidder will be required to provide a certificate of insurance and proof of manufacturers certification for the equipment being offered and any applicable State of Connecticut licenses for the work being performed. All bids must clearly state the equipment warranty information and the successful firm will supply a warranty on labor for a period of two years from the date of completion to cover installation issues or service under the length of the manufacturer's warranty. Ledyard Public Schools is attempting to standardize the projector and smart TV equipment across all schools so alternate brands of equipment will not be accepted. Alternate models will be considered if they meet the minimum specifications of the original equipment. Bid package must include cut sheets for all the equipment being provided as part of the bid.

Signed Drawings Required To Process Order

Project Name: Ledyard HS Project #: A235457 Phase: 01 Rev: 1



www.midmark.com
design@midmark.com
Phone: 1-800-MIDMARK

Special Quote

(Signature) _____ (Date) _____

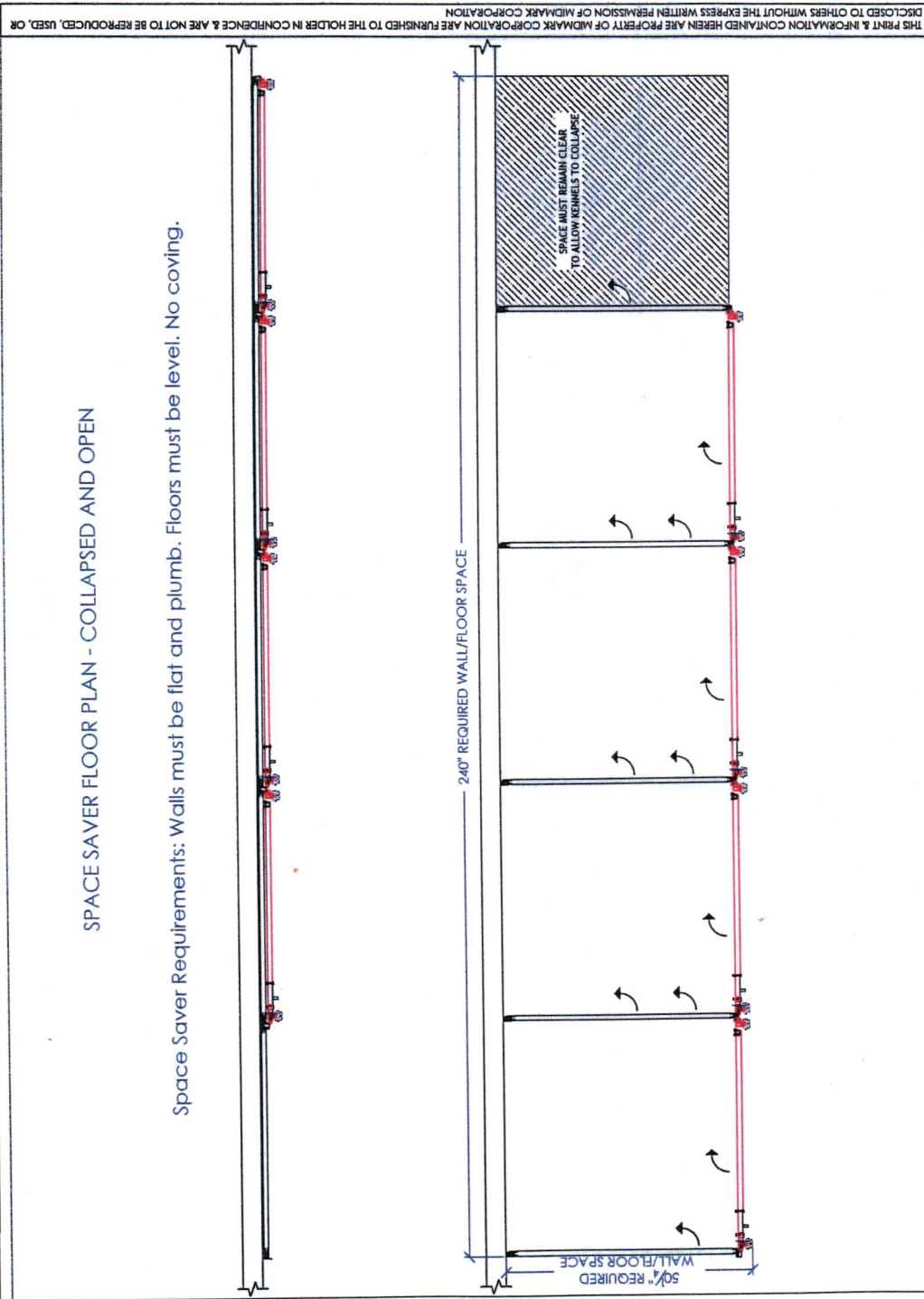

SPACE SAVER FLOOR PLAN - COLLAPSED AND OPEN

Space Saver Requirements: Walls must be flat and plumb. Floors must be level. No coving.

PROJECT: LEDYARD HS	DESIGN: A. BAILEY	QUOTE: A235457-1	DATE: 9/14/2023
		PROJECT: A235457	

THIS PRINT & INFORMATION CONTAINED HEREIN ARE PROPERTY OF MIDMARK CORPORATION ARE FURNISHED TO THE HOLDER IN CONFIDENCE & ARE NOT TO BE REPRODUCED, USED, OR DISCLOSED TO OTHERS WITHOUT THE EXPRESS WRITTEN PERMISSION OF MIDMARK CORPORATION

Signed Drawings Required To Process Order

Rev: 1

Phase: 01

Project #: A235457

Project Name: Ledyard HS

(Signature) _____ (Date) _____

Special Quote

midmark®
 www.midmark.com
 design@midmark.com
 Phone: 1-800-MIDMARK

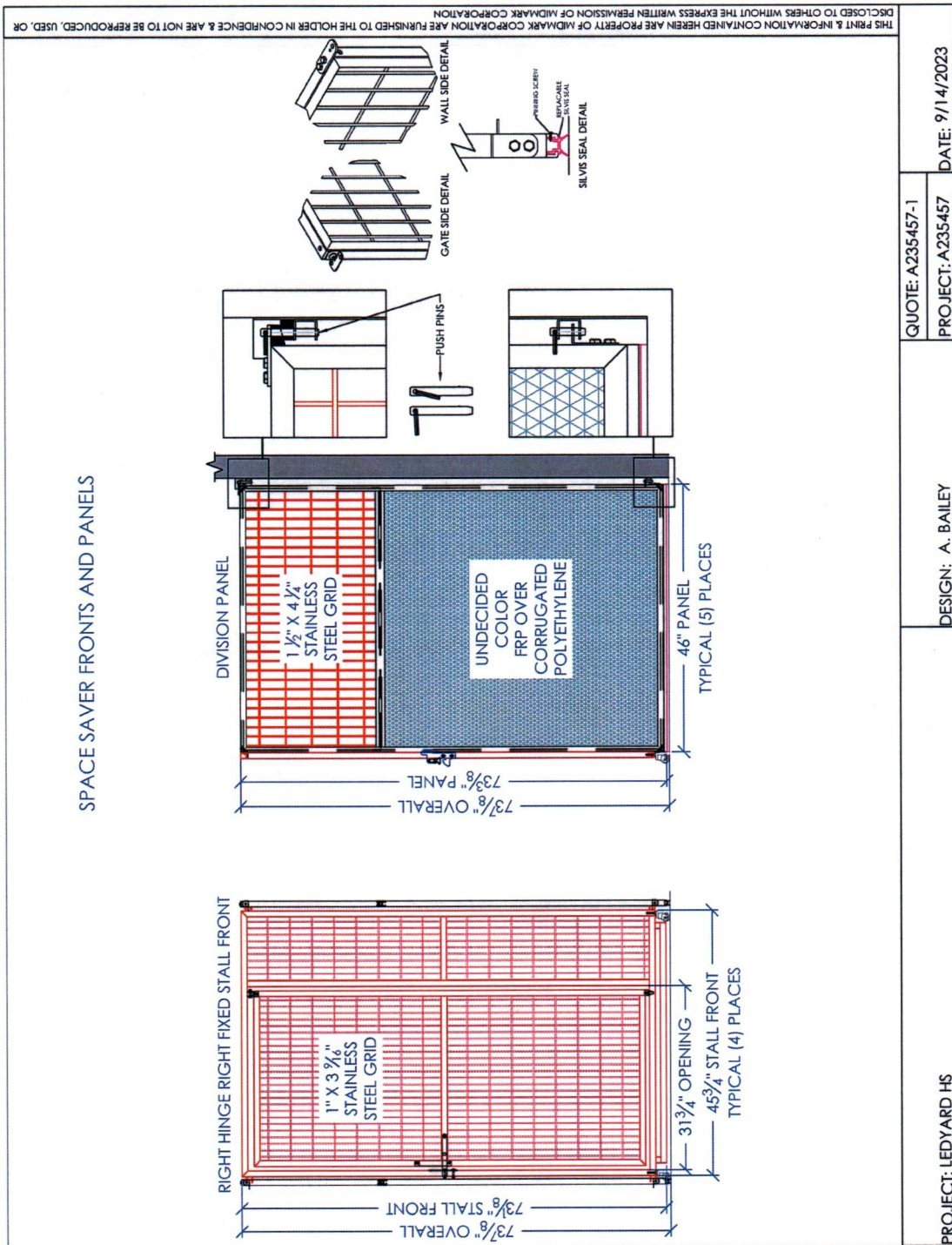

PROJECT: LEDYARD HS	DESIGN: A. BAILEY	QUOTE: A235457-1
		PROJECT: A235457
		DATE: 9/14/2023

Space Savers & Cat Towers

Drawing Template: -

Revision: -

Change Order: -

5/8

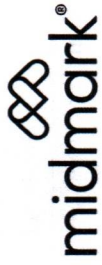

www.midmark.com
 design@midmark.com
 Phone: 1-800-MIDMARK

Project Name: Ledyard HS

Project #: A235457

Phase: 01

Rev: 1

Special Quote

Signed Drawings Required To
 Process Order

(Signature)

(Date)

CAT TOWER FLOOR PLAN

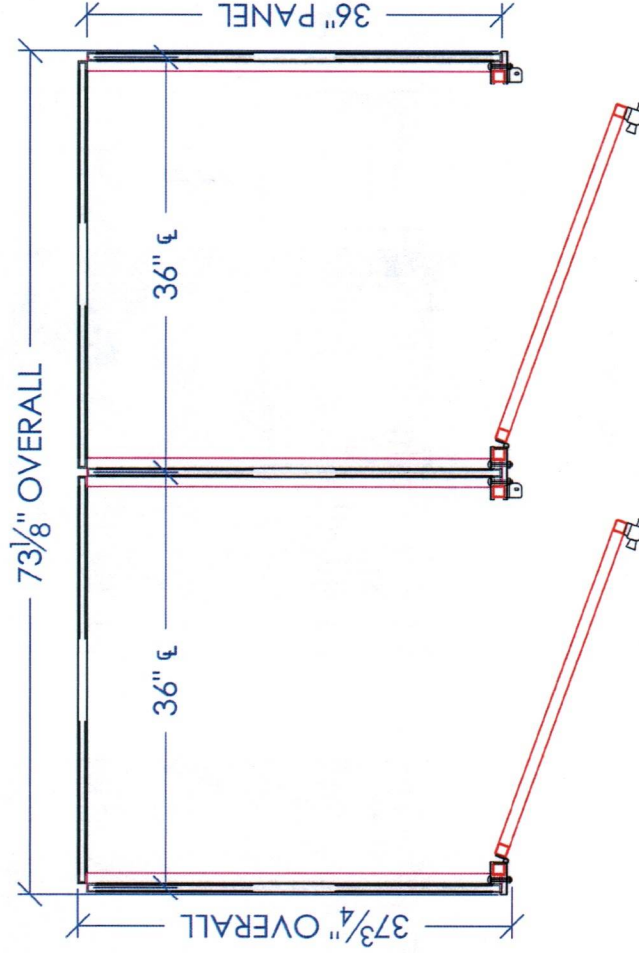

THIS PRINT & INFORMATION CONTAINED HEREIN ARE PROPERTY OF MIDMARK CORPORATION AND ARE NOT TO BE REPRODUCED, USED, OR DISCLOSED TO OTHERS WITHOUT THE EXPRESS WRITTEN PERMISSION OF MIDMARK CORPORATION

QUOTE: A235457-1
 PROJECT: A235457
 DATE: 9/14/2023

DESIGN: A. BAILEY

PROJECT: LEDYARD HS

Space Savers & Cat Towers

Drawing Template: -

Revision: -

Change Order: -

6/8

Signed Drawings Required To Process Order

Rev: 1

Phase: 01

Project #: A235457

Project Name: Ledyard HS

midmark[®]
 www.midmark.com
 design@midmark.com
 Phone: 1-800-MIDMARK

Special Quote

(Signature)

(Date)

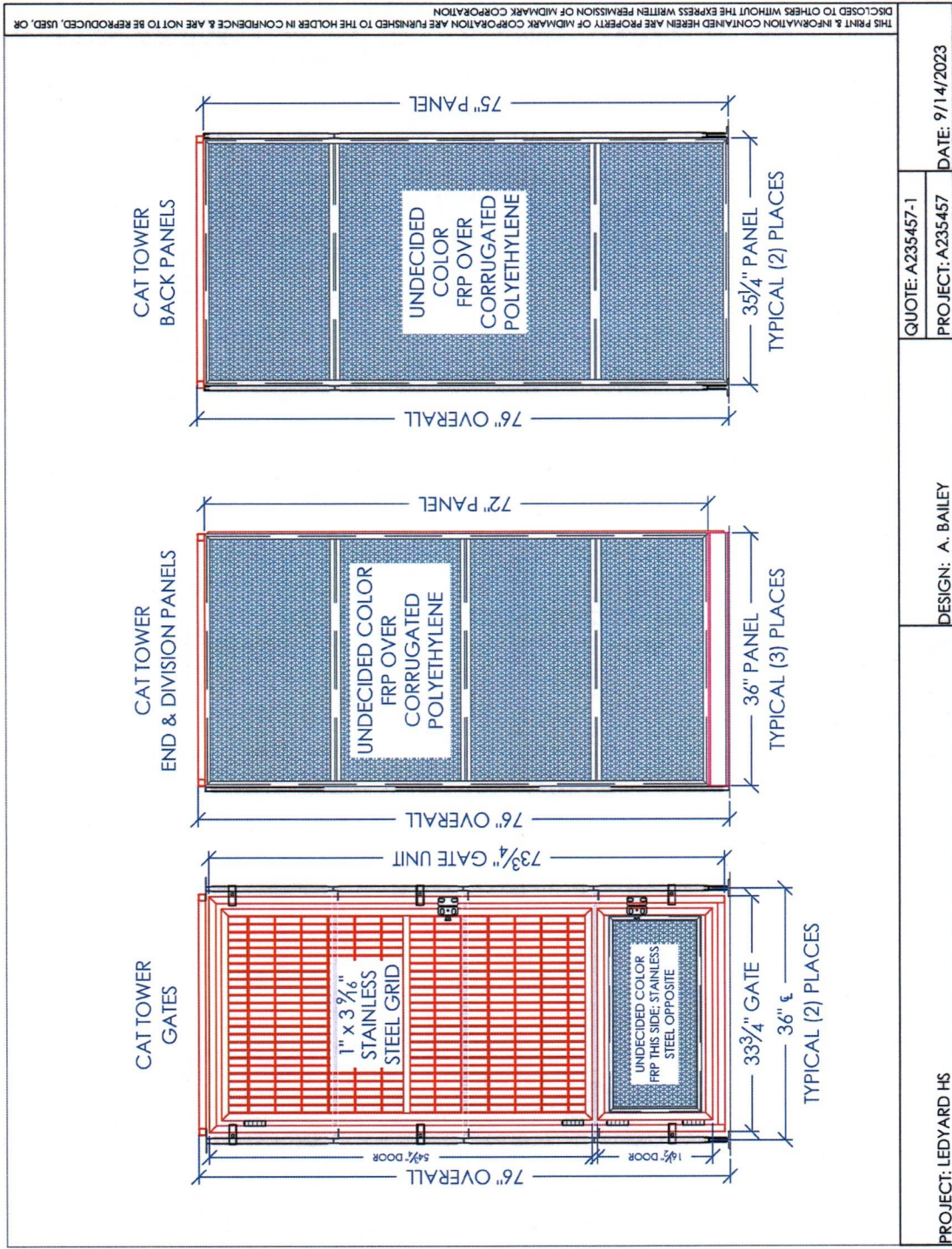

Space Savers & Cat Towers

Drawing Template: -

Revision: -

Change Order: -

7/8

Project Name: Ledyard HS
Project #: A235457
Phase: 01
Rev: 1

Signed Drawings Required To
Process Order

Special Quote

(Signature) _____ (Date) _____

www.midmark.com
design@midmark.com
Phone: 1-800-MIDMARK

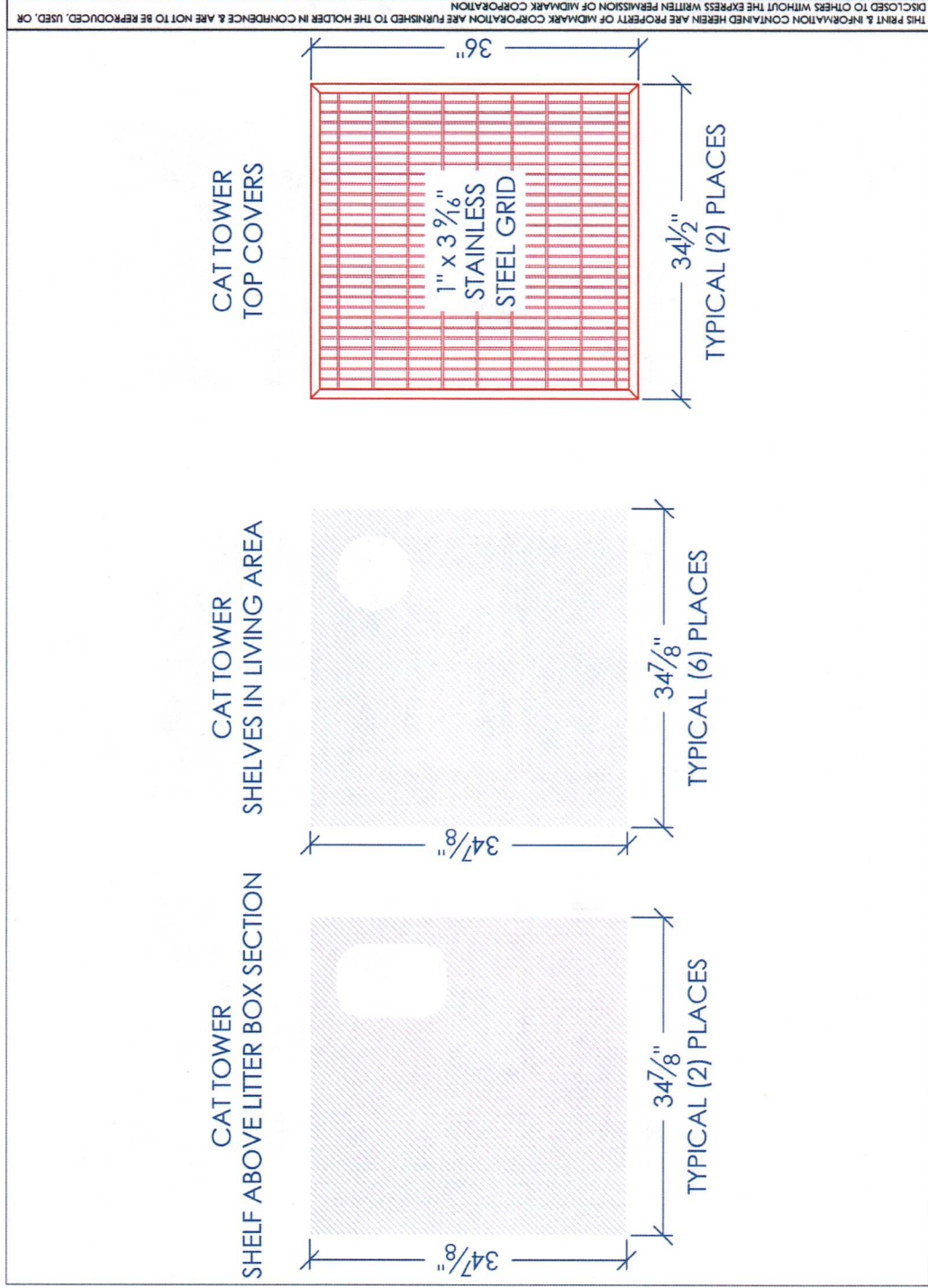

PROJECT: LEDYARD HS	DESIGN: A. BAILEY	QUOTE: A235457-1	DATE: 9/14/2023
		PROJECT: A235457	

Space Savers & Cat Towers